

Ultimate Woofer
 Ø 10", Ø 5.1" voicecoil, 4Ω



FEATURES

- Uniflow™ Aluminum diecast chassis
- High flux double Ferrite magnet system
- 5.1" Large Hexatech™ Aluminum voice coil
- One piece paper cone/center dome
- Accucenter™ self centering cone assembly
- Improved parameters
- PFS™ Progression Field Symmetry spider/surround engineering

UNIT DIMENSIONS

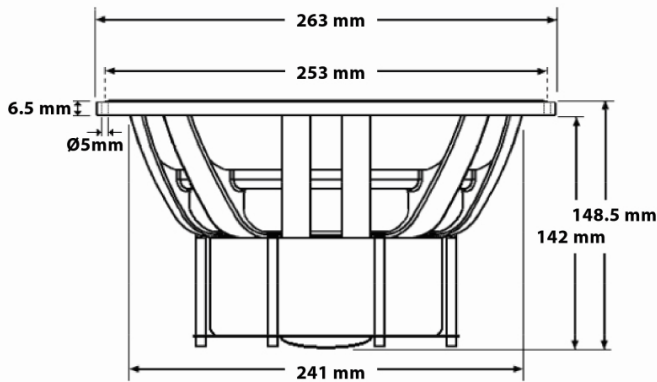

SPECIFICATIONS

General Data

Overall Dimensions (DxH)	263mm(10.35")x148.5mm(5.84")
Nominal Power Handling (DIN)(P)	500W
Transient Power 10ms	1500W
Sensitivity (2.83V/1M) dB	88dB
Frequency Response Hz	See graph
Dome Material	Composite cellular fiber
Net Weight (Kg)	6.5

Electrical Data

Nominal Impedance (Z)	4Ω
DC Resistance (Re)	3.55Ω
Voice Coil Inductance 1KHz (LBM)	1.0 mH

Voice Coil and Magnet Parameters

Voice Coil Diameter (DIA)	130mm
Voice Coil Height	37mm
HE Magnetic Gap Height (HE)	12mm
Max. Linear Excursion (X)	± 12.5mm
Voice Coil Former	Aluminum
Voice Coil Wire	Hexatech™ Aluminum
Number Of Layers	2
Magnet System Type	High flux double ferrite
B Flux Density (B)	0.63 T
BL Product (BXL)	11.8 N.A

T-S Parameters

Suspension Compliance (Cms)	0.51 mm/N
Mechanical Q Factor (Qms)	1.43
Electrical Q Factor (Qes)	0.35
Total Q Factor (Qts)	0.29
Mechanical Resistance (Rms)	9.78 Kg/s
Moving Mass (Mms)	102 g
Eq. Cas Air Load (liters)(VAS)	86.5 Lt
Resonant Frequency (Fs)	22 Hz
Effective Piston Area (SD)	346 cm ²

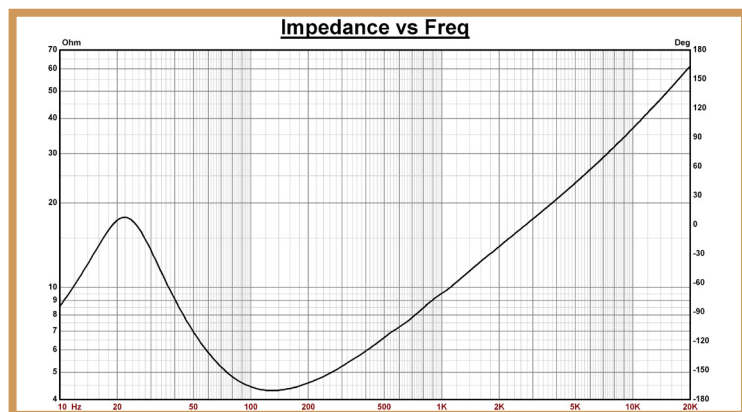

Driver is mounted rigidly in free air with no baffle or enclosure. Input signal is a stepped sinusoidal at 1VRMS. Impedance is measured using constant-voltage method. No smoothing Driver is mounted rigidly in free air with no baffle or enclosure. Input signal is a stepped

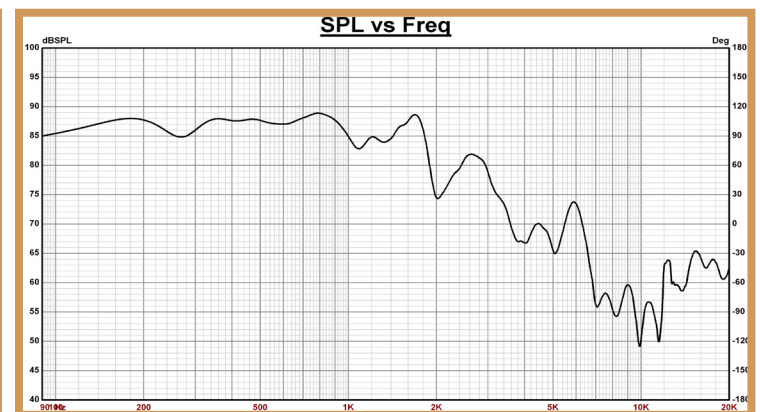

Driver was mounted rigidly on an IEC baffle. Microphone distance is 0.5m, input voltage Driver was mounted rigidly on an IEC baffle. Microphone distance is 0.5m, input voltage 2.83VRMS and normalized to 1m. 1/12 octave smoothin

*Morel operates a policy of continuous product design improvement, consequently specifications are subject to alteration without prior notice.